

# Optical properties of eye lens

---

**Hinnawi, Zaki**

**Master's thesis / Diplomski rad**

**2018**

*Degree Grantor / Ustanova koja je dodijelila akademski / stručni stupanj:* **University of Zagreb, School of Medicine / Sveučilište u Zagrebu, Medicinski fakultet**

*Permanent link / Trajna poveznica:* <https://um.nsk.hr/um:nbn:hr:105:839642>

*Rights / Prava:* [In copyright](#)/[Zaštićeno autorskim pravom.](#)

*Download date / Datum preuzimanja:* **2025-03-13**



*Repository / Repozitorij:*

[Dr Med - University of Zagreb School of Medicine Digital Repository](#)



**UNIVERSITY OF ZAGREB  
SCHOOL OF MEDICINE**

**Zaki Hinnawi**

# **Optical properties of eye lens**

**Graduate thesis**



**Zagreb, 2018.**

This graduate thesis was made at Department of Physics and Biophysics mentored by Pr. Dr. Sanja Dolanski Babic and was submitted for evaluation (2017/2018).

## Abbreviation

C.....	Center of curvature
c.....	Speed of light in vacuum
F.....	Focal point
$f$ .....	Focal length
$H_i$ .....	Height of image
$H_o$ .....	Height of object
M.....	Magnification
$n_a$ .....	Refractive index of air
$n_i$ .....	Refractive index of incident medium
$n_L$ .....	Refractive index of lens
$n_t$ .....	Refractive index of transmitted medium
R.....	Radius
$S_i$ .....	Distance from object
$S_o$ .....	Distance from image
V.....	Vertices
$v_n$ .....	Speed of light in medium
$X_i$ .....	Angle of incidence
$X_r$ .....	Angle of reflection
$X_t$ .....	Angle of transmission/refraction

# Contents

Summary

Sažetak

1. Introduction.....	1
2. Geometrical Optics.....	2
2.1. General .....	2
2.2. Principal light rays .....	3
2.3. Refraction of the light.....	3
2.4. Reflection of the light .....	5
2.5. Image characteristics.....	6
3. Mirrors.....	9
4. Lenses .....	14
4.1. General .....	14
4.2. Lens-Maker's equation .....	15
4.3. Lenses .....	16
5. Anatomy of Human Eye.....	19
5.1. Introduction.....	19
5.2. Anterior Chamber .....	20
5.3. Posterior Chamber .....	21
6. Refractive media of eyeball.....	23
7. References.....	28
8. Acknowledgment.....	29
9. Bibliography.....	30

## **Summary**

Title: Optical property of eye lens

Author: Zaki Hinnawi

In this thesis we will cover the optical properties of the human eyeball, we will do that by first covering the basics of geometrical optics, we shall explain what happens to light at an interface and show how to calculate these changes. Once we have covered the basics we will go into more detail and see how images are formed using different optical laws, starting from a plain mirror and ending with a thick lens. After having covered basic optics so we can understand the first part of our title, optical properties, we will go into the anatomy of the human eyes, and describe each structure making up the eyeball, we will also show the different functions of those structures and how they all work together.

Lastly, we will describe the parameters of the regular human eye and describe the optical properties of the structures making it up separately, and finally we will conclude by showing an optical model of the eye to show how it all looks.

Keywords: Optical properties, Light interface, Geometrical optics, Lens, Eye, Optical model.

## **Sažetak**

Naslov: Optička svojstva očne leće

Autor: Zaki Hinnawi

Cilj ovog rada je opisati optička svojstva ljudskog oka. U prvom dijelu rada objasniti ću osnove geometrijske optike kao npr. što se događa sa zrakom svjetlosti na granici dva sredstva različitih indeksa loma, kako nastaje slika na ravnom i sfernom zrcalu te na tankoj i debeloj leći. Nakon što sam definirao optička svojstva, prvi dio naslova, opisat ću anatomiju ljudskog oka, strukturu očne jabučice, također ću pokazati kako te strukture funkcioniraju zajedno.

Na kraju, opisati ću parametre zdravog ljudskog oka i optička svojstva struktura te ću prikazati model oka.

Ključne riječi: optička svojstva, svjetlost, geometrijska optika, leće, oko, optički model

## 1. Introduction

This thesis will be discussing the properties of the eye lens, but before doing that one has to have the following: a good concept of geometrical optics, knowledge concerning the anatomy of the eye and an understanding of the purpose of the lens in the overall optical capability of the eye. Since knowing the following is crucial, in this thesis we will describe each one separately and explain the basic knowledge behind them, concluding with the description of the lens and its optical properties.

There are many other studies about optics in physics and each is ultimately dealing with light, some explaining its nature as a wave, while others view it more like a particle and are concerned with light's interaction with matter. This thesis will focus on geometrical optics, which is the study of light propagation and image formation using geometrical principles. [1]

While we will only discuss geometrical optics, I would like to state a few basic facts known about light, this is necessary for a better understanding of why light behaves the way it does. As is known, visible light is part of the electromagnetic spectrum, having a wavelength from about 390nm (violet) to 780nm (red), and as it travels it will interact with particles in its path, this interaction was explained long ago by Lord Rayleigh in 1871, and is called Rayleigh Scattering, this submicroscopic level of interaction is what leads to the macroscopic processes of transmission, reflection and refraction. [2]

(Some figures used in this thesis are made to resemble optical systems of different optical tools, they represent the situation fairly correct and may be made by hand.)



## 2. Geometrical Optics

### 2.1. General

Geometrical optics is a special part of physics in which we use straight lines to visualize the light ray path and consider a light ray to travel in a continuous direction when it is found in a uniform medium. Light rays will only bend at the interface between two media, and to understand that more, we will discuss in more detail what happens at that interface [3]. When talking about different uniform media, we usually state their refractive index. The refractive index of a medium can be calculated as, the speed of light in vacuum, divided by, the speed of light in that medium, the difference in speeds is brought about by the interaction of light with particles and is what causes light to change direction. In a vacuum; where there are no particles and therefore light has no interaction, the refractive index is 1.000, but for another medium, it can be calculated as:

$$n = \frac{c}{v} \quad (1)$$

Where  $n$  stands for the relative index,  $c$  is the speed of light which is  $3 \cdot 10^8$  m/s, and  $v$  is the speed of the light in the certain medium.

Law of rectilinear propagation is used in optics and was mentioned earlier when explaining light rays in geometrical optics. This law states that a ray of light in a homogeneous medium will move in a straight line and does not take into account diffraction as light is traversing the medium. This is the difference between physical and geometrical optics, since this thesis is leaning more towards medicine and the use of optics in the human eye, it will not mention diffraction, since there are rare clinical cases with errors caused by diffraction. [1]

## 2.2. Principal light rays

Principal light rays are used in geometrical optics when drawing schemes. They are used for the simple reason because it would be almost impossible to draw every ray of light coming from a source and reflecting or refracting of an object. When using schemes to find an image of a certain object found in an optical system, it is necessary to use two or more rays originating from the same point so that we can show where they meet, to illustrate where the image would be formed, this is called raytracing. When talking about rays it will often be mentioned which ray it is; incident, reflected or refracted, also most often with its accompanying angle at which it meets the boundary between two media, this angle is always taken from the so called normal, or principal axis that is always drawn perpendicular to the boundary of the new medium. [2]

## 2.3. Refraction of the light

Refraction, also called transmission, happens when a ray of light from one medium, enters another medium and changes its direction. The incident ray has to enter the medium at an angle larger than zero with respect to the normal, found perpendicular to the surface of the medium, to have refraction [2]. Up to this point I have mentioned index of refraction and how to calculate it, now I will show how it can be useful when one is dealing with how a ray of light will behave when going from one medium to another. To start I shall state Snell's law [4] which shows an association between the refractive indices, and the angles of incidence and transmission.

$$n_i \sin(\theta_i) = n_t \sin(\theta_t) \quad (2)$$

Where  $n_i$  and  $n_t$  are the refractive indices of the incident medium and transmitting medium respectively, while  $\theta_i$  and  $\theta_t$  stand for the incident and refracted angles with respect to the normal on the surface.

As a rule, which can also be shown using the equation, when a ray of light travels from a medium of a low refractive index to a medium of a high refractive index, the light will bend towards the normal, and vice versa is also true, meaning light coming from a

medium of high refractive index to a medium with a low refractive index, will refract light ray away from the normal [4].

To understand refraction better, we can look at Figure 1 which shows a light ray reflecting and refracting in three different cases. Looking at part a) of the figure, we see that the light entering a material with a larger index of refraction bends towards normal, and on the b) part we can see that light entering a medium with smaller index of refraction bends away from the normal, and finally on the c) part we can see that light entering at the normal to the surface does not bend. All these three examples are special cases and can be found using equation (2).

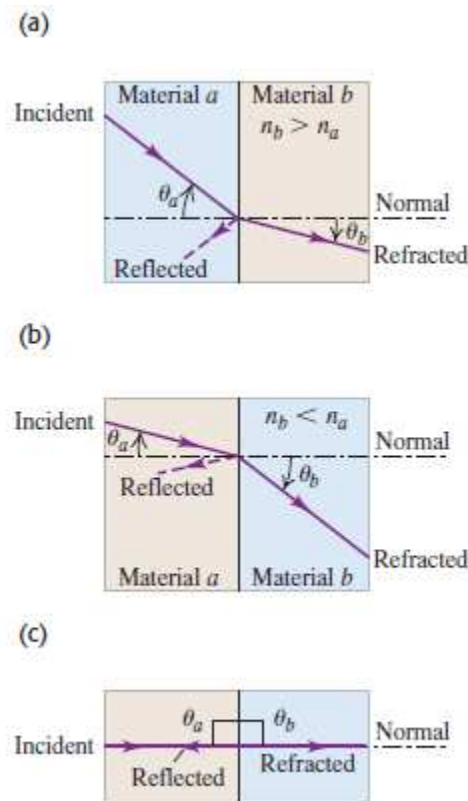

Figure 1. Reflection and refraction index for three different cases. a) Material b has a larger index of refraction than material a. b) Material b has a smaller index of refraction than material a. c) The incident ray is the normal to the interface between materials [9].

## 2.4. Reflection of the light

Reflection occurs every time light travels from one medium to another and in certain conditions light can be made to only reflect and not refract from one medium to another. When these conditions are met we have total reflection, this occurs when light travels from a medium with a high index of refraction, to a medium with a low refractive index, at a so called critical angle, or better said, when the angle of incidence is equal to, or larger than the critical angle, then the following incident ray will be totally reflected. The critical angle for a medium can be calculated from its index of refraction using Snell's law (mentioned earlier), and this concept is abused in medicine, where we use different materials with different indices of refractions to make optic fibers that are very useful in getting light to go to places that otherwise seemed impossible as shown on figure 2.

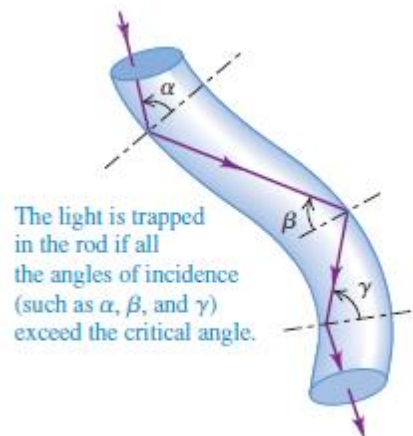

Figure 2. Optical fiber. Refraction index of the rod is greater than the index of the surrounding air. [9]

The 3 laws of reflection which can be derived from the Fresnel equation, state the following [1]:

- a) The incident ray, the reflected ray and the normal all lie in the same plane called the plane-of-incidence.
- b) The incident ray and reflected ray are on opposite sides of the normal.
- c) The angle of incidence (angle between incident ray and normal) is equal to the angle of reflection (angle between the reflected ray and normal).

Imagine a ray of light traveling perpendicularly towards a plain mirror and coming into contact with it at a  $90^0$  angle, the following light will reflect back on its path, this is an example of what we call specular reflection, another type is called, diffuse reflection, and it occurs when light meets a rough surface, unlike a plain mirror, and is reflected in all directions. If you would apply the former situation of a ray of light meeting a “rough” surfaced mirror at a  $90^0$  angle, then the light will not only reflect back on its path but also in every other direction [4]. This can also occur with refraction, if the light where to enter a new medium that has a rough boundary, it will cause the light to refract at different angles, in this thesis all forms of reflection and refraction are to be considered specular as displayed on figure 3 (a).

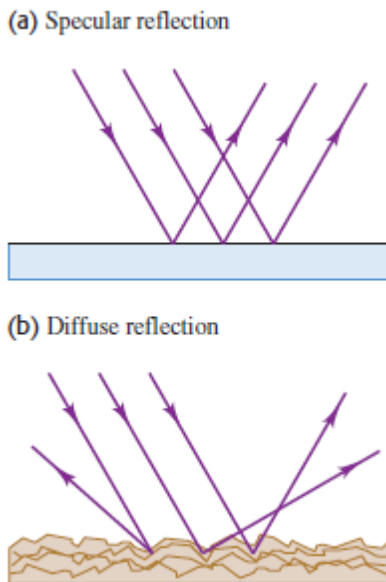

Figure 3. Two different types of reflection [9]

## 2.5. Image characteristics

Images are described in several ways, the configuration of it, its size and its location, these can be shown and calculated using schemes in geometrical optics and using a technique called raytracing as mentioned earlier. [1]

An image is a scale model of the object. When the image is upright, or one can say when it extends upwards from the optical axis, it is denoted with a “+” sign, and when the image is reverted it’s denoted with a “-“ sign [1]. Another difference between images is whether they are virtual, or real, and one can distinguish the two by looking at the rays making the image. If the rays coming from the object meet and form the image, it is said to be real, while if the rays don’t actually meet but are rather traced back to form an image, we can say that the image obtained is virtual. Most often one can find the combination of an image being real or virtual, and upright or inverted.

Another concern is the size of the image in relation to the object and this is referred to as magnification, there are three different types of magnification in geometrical optics and they are:

- a) Transverse
- b) Angular
- c) Axial.

The ratio of the height of the image, to the height of the object (height is taken from the principal axis), is transverse magnification. Angular magnification is the ratio of the angular height subtended by an object viewed by the eye under a magnifying lens, to the angular height subtended by the object viewed by the eye without the magnifying lens. Axial magnification, also known as longitudinal magnification, is the ratio of length of image, to length of object, also measured along the principal axis. [1]

Now that we covered magnification, one should mention that it is usually denoted using the multiplication sign “X”, also the word power is usually used interchangeably with transverse magnification to state the “power” of a certain lens or mirror, although this should be avoided since it can be misleading because power has several different meanings. [1] Most of the time when getting an image we state its transverse magnification, and put a plus or minus sign in front of it to state whether the image is upright or inverted respectively. For example if an object with height of 2 cm gives an inverted image with height of 4 cm, since the image is inverted the height of the image is taken from below the principal axis and is negative, giving the overall transverse magnification a negative value of 2 or -2.

Lastly, image location, this is important since we often encounter errors that can change the location of the image, an example would be refractive errors found in humans that causes the image to form behind or in front of the retina. The distance to the image is always measured along the principal axis (in meters), from a relative point on the lens called the vertex, there are two vertices and they can sometimes overlap with the nodal points, but mostly they represent the apex of the lens's curvature on both sides of the lens [1]. When measuring the distance to the left side of the interface, we assign a negative value and when measuring to the right side we assign a positive value.

### 3. Mirrors

After we described reflection and refraction, we will now apply them by taking a look at schemes of how images are obtained in life, using mirrors and lenses. Starting with mirrors, there are two types:

- a. plain mirrors (flat mirrors)
- b. spherical mirrors (curved mirrors).

Plain mirrors are found everywhere and everyone encountered a plain mirror in their life, whether it is in the bathroom or at a cloth store. Plain mirrors, as most of us know, give us an identical image, not only in size and shape but also in the distance, these images are upright, virtual images and are located as far in the mirror as the object is in front of it as one can see on figure 4. We can see easily how mirror creates image with a simple scheme and using the raytracing technique. [4]

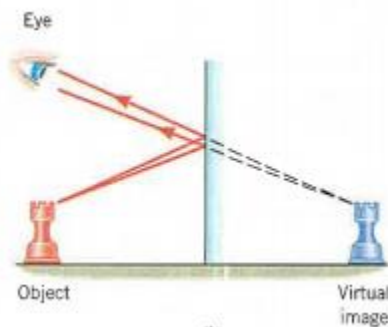

*Figure 4. Image being created by the plane mirror [4]*

Figure 4 shows two rays of light originating from an object and reflecting off a plain mirror into the observer's eye. One can see that the two rays of light are diverging as they are traveling away from the mirror, and when one traces them back they appear to come from within the mirror, from this fact we can say the image is virtual. The image is also upright, so when we describe the image obtained by the mirror we say it has a value of +1 since it is upright and has the same size as corresponding object, this is true to all plain mirrors. The angle of incident is equal to the angle of reflection, the reason for this was stated earlier with the laws of reflection.



Spherical mirrors have two main types, convex and concave. While until now we have dealt with linear optical tools, like plain mirror, this is not the case when looking at spherical mirrors which are curved. With curved optical tools, one has a set of rules to use and additional points on the optical system that aid with drawing schemes and finding the image formed. Unlike plain mirrors which simply reflect the light, spherical mirrors can diverge or converge incoming rays depending on its shape, although this divergence and convergence are achieved by reflection, which is not the case when talking about lenses and we will see that later.

When dealing with curved optical tools the optical system has some additional points and they are:

- a) Center of curvature (C), this point is located on the principal axis and is actually, as the name says, the center of the spherical mirror. We can deduce that the distance from the mirror to center of curvature is equal to the radius (R) of the mirror.
- b) Focal point (F) is also found on the principal axis and it's the point to which all parallel rays coming towards the spherical mirror will be focused to (concave) or seem to be coming from it (convex). Focal length, which is the distance from the mirror to the focal point and can be calculated as (4):

$$f = \frac{R}{2} \quad (3)$$

Where  $R$  is radius of curvature, and  $f$  stands for the focal length.

To find the location of an image in an optical system containing a curved optical tool, we use 3 special rays that behave in a known manner.

Although these rays might look as if they behave differently according to the type of spherical mirror or lens used, concave or convex, they actually follow the same rules which are [4]:

- 1) Any ray traveling parallel to the principal axis, will reflect towards the focal point (concave mirror), or can be traced back towards the focal point (convex mirror).

- 2) Any ray traveling towards the center of curvature will be reflected back on its path.
- 3) Any ray that passes the focal point before reaching the mirror (concave), or travels towards the focal point (convex), will reflect back and travel parallel to the optical axis.

After having said all this, we can now take a look at geometrical schemes to get a better visualization. On Figure 5 there are two schemes, 5a shows a concave mirror and 5b shows a convex mirror, as we can see the 3 rays mentioned above are used in both figures to find the location of the image [4].

Figure 5a, shows a concave mirror with its 3 rays:

- a) The first ray is traveling parallel to the principal axis and is therefore reflected towards the focal point  $F$ .
- b) The second ray traverses the principal axis at the focal point  $F$  and is reflected parallel towards the principal axis
- c) Lastly, third ray traverses the center of curvature  $C$  found on the principal axis and is reflected back on its path.

Image formed by this concave mirror is real, inverted and smaller than the object. It's worth pointing out that concave mirror can create different pictures depending on the distance of the object from the mirror.

Figure 5b, shows a convex mirror, the first difference that can be seen is the positioning of the points found on the principal axis, these points appear to be inside the mirror and are therefore said to be virtual, following the three rays in this scheme we can already see that the rays are not actually converging and meeting but rather diverging away from each other and the image is formed by tracing back the path of the reflected rays, as if they were to come out of the mirror.

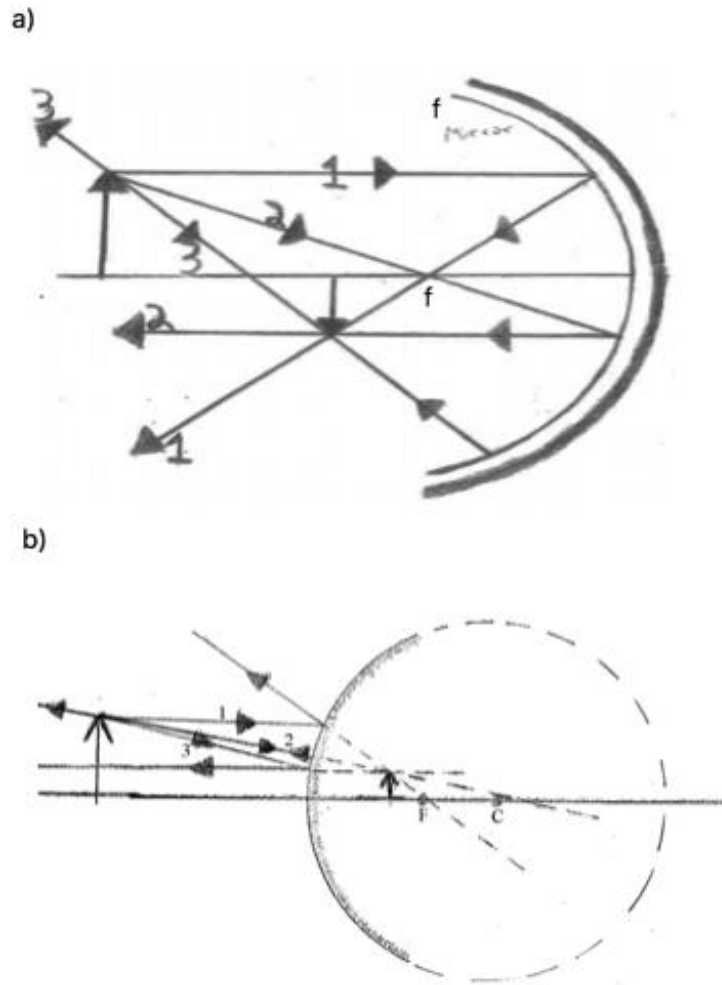

Figure 5. Principal rays for a) concave mirror and b) convex mirror

Three main rays for the convex mirrors are:

- a) The first ray, travels towards the mirror parallel to the principal axis and is reflected, when tracing back the reflected ray it appears to come from the virtual focal point inside the mirror.
- b) The second ray, travels towards the virtual focal point  $F$  inside the mirror but is reflected parallel to the principal axis.
- c) Finally, the third ray, travels towards the virtual center of curvature  $C$  and is reflected back on its path before reaching it.

The image formed by this mirror is virtual, upright and smaller than the object itself. Same as with concave mirror, convex mirror can create different pictures depending on the location of the object from the mirror

The mirror equation states the following [4]:

$$\frac{1}{f} = \frac{1}{s_o} + \frac{1}{s_i} \quad (4)$$

Where  $s_o$  is distance from object to the mirror,  $s_i$  is distance from picture to the mirror, and  $f$  is focal length.

This equation can be deduced based on geometry and some algebraic elimination of the following two equations [4]:

$$-\frac{H_o}{H_i} = \frac{S_o}{S_i} \quad (5)$$

$$-\frac{H_o}{H_i} = \frac{S_o - f}{f} \quad (6)$$

Where  $H_o$  is height of the object, and  $H_i$  is height of the picture.

## 4. Lenses

### 4.1. General

One of the first differences that can be spotted between lenses and mirrors is their optical system. While a spherical mirror has only a one sided curvature and simply reflects light, the lens has two curved sides and allows light to be transmitted through it. Due to its two curved sides, the lens's optical system contains two center of curvatures and two focal points, other points found in lenses and not mirrors are vertices. There are two of vertices and they are found on opposite sides of the lens and are the point that mark the apex of the lens on either side, these points are used as references when calculating distances on the principal axis, the distances are negative for any point found on incident plane of the lens and positive for points found in the transmitted plane of the lens [5].

Lenses' optical systems have two nodal points, sometimes these two points overlap and seem to appear as one point. These nodal points are found on the principal axis inside the lens and are special since when a ray of light coming from a source or object intersects the principal axis at one of the nodal points, that ray will leave the optical axis from the other nodal point. Two angles formed by the ray of light and the optical axis are said to be equal, and because of this property nodal points are used to establish a relationship between transverse magnification, object distance, and image distance. When viewing this relationship and applying basic geometry we get the following; regardless of where the object is found, the object and the image form equal angles with respect to their nodal points, having said that we can state the following [1]:

$$\text{transverse magnification} = \frac{\text{Image height}}{\text{Object height}} = \frac{\text{Image distance}}{\text{Object Distance}}$$

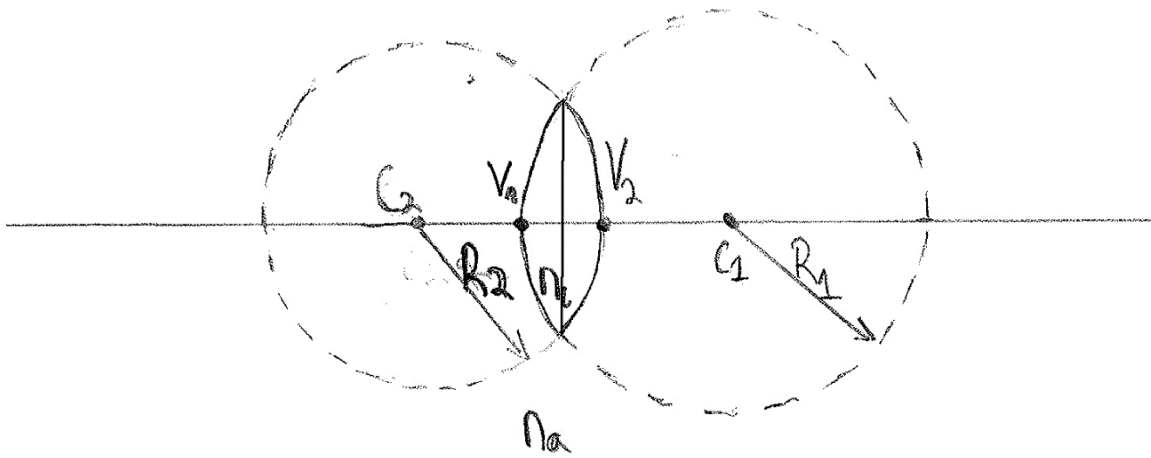

Figure 6. Optical system of lens

Figure 6 gives us a better visualization of the points mentioned earlier and how the overall optical system of a lens looks like, we can visualize those two radii by taking an example of a thin convex lens and completing the two circles from the two curvature found on a lens. [2]

#### 4.2. Lens-Maker's equation

Lens-Maker's equation describes the relationship among the focal length  $f$ , the index of refraction  $n$  of the lens, and radii of curvature  $R_1$  and  $R_2$  of the lens surfaces. We will be using the principle that an image formed by one reflecting or refracting surface can serve as the object for the other refracting surface. [9]

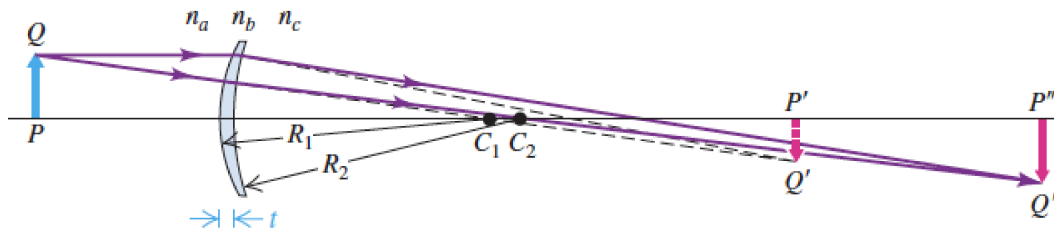

Figure 7. Image formation by lenses. Indexes of refraction  $n_a$  and  $n_b$  are the same. [9]

The Lens-Maker's equation states the following for a lens in the air [5]:

$$\frac{1}{f} = (n - 1) \left( \frac{1}{R_1} + \frac{1}{R_2} \right) \quad (7)$$

In equation 7 we can see clear that the focal length of a certain lens is related to its index of refraction  $n$  and to its radii of curvature  $R_1$  and  $R_2$ . Notice that this lens is in the air, if it weren't in the air but in another medium then the Lens-Maker equation would look the same but rather having  $n - 1$  we will have  $n - n_m$ , where  $n_m$  is the refractive index of the medium the lens is found in. [5]

One should also note that when using this equation it doesn't matter what side of the lens faces the incident light and if the two radii of curvature are different, the only thing one should be concerned with when using this equation is that the radii of curvature have a positive value for convex lenses and a negative value for concave lenses. [5]

Another formula that can be found using the lens-maker's equation, and is fairly similar to the mirror equation, is the Gaussian lens formula: [5]

$$\frac{1}{f} = \frac{1}{s_o} + \frac{1}{s_i} \quad (8)$$

This formula, like the mirror equation, relates the focal length of a lens, to the distance of the object and the distance of the image obtained. As mentioned earlier all distance values are measured in meters, and from this formula we get a value with a unit of  $m^{-1}$ , this reciprocal of meter is used in optics and is called diopter, and often it is used to represent the refractive power of a lens, often the term power alone is used and put in an equation it appears like the following [5]:

$$P = \frac{1}{f} [1m^{-1} = 1 \text{ dpt}] \quad (9)$$

### 4.3. Lenses

When looking at lenses there are two different types and these are similar to the types of spherical mirrors, they are concave or convex. Another difference that can be made in lenses is the thickness of the lens meaning we can have, thick lenses, or thin lenses and that has an effect in a certain equation that is used to make a lens, although I will not go

too much into thick lenses since the lens and all other optical structures found in the human eye are considered to be thin lenses when viewed separately, it is important however that the reader knows that the whole eye together should be viewed more as a thick lens made up of thin lenses.

Figure 8 and 9 show the two types of thin lenses, convex and concave, and as we can see the same method of ray tracing is used as in mirrors. Three rays are used originating from the same point found on an object and merge towards that same point on the image of said object.

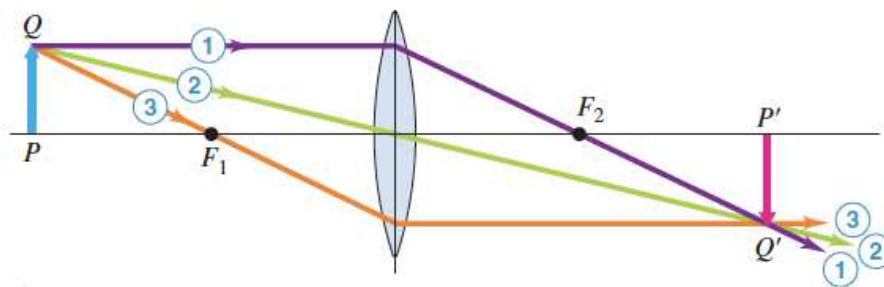

Figure 8. Convex or converging lens [9].

Figure 8, shows a convex lens with the three rays used in ray tracing to find the image location, as we can see the first ray is traveling parallel to the optical axis and converges towards the second focal point, the second ray passes through the center of the lens (where it meets the principal axis), this ray is similar to the third ray found in spherical mirrors, since it will not refract but continue traveling in a straight line. The third ray traverses the focal point before reaching the lens and is therefore refracted parallel towards the optical axis.



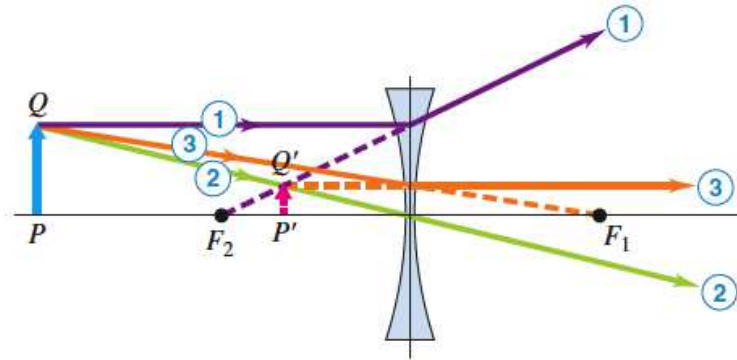

Figure 9. Concave or divergent lens [9].

Figure 9, shows a concave lens with its three rays used in ray tracing, the first ray travels towards the lens parallel to the principal axis and is diverged away from it as it passes the lens, tracing back the path of the refracted ray it seems as if it is coming from the focal point. The second ray travels to the center of the lens and its not refracted. Finally, third ray travels towards the focal point found on the opposite plane of the lens and is refracted parallel to the principal plane.

Looking back to the figures 8 and 9, to conclude we can say that the image made by this convex lens is a real, inverted image and that is bigger than the object itself, while the image made by this concave lens is a virtual, upright image that is smaller than the object. As with the mirrors, image formation can greatly depend on the position of the object relative to the lens.

When dealing with curved optical tools, especially lenses, all of them suffer from various defects in achieving a good quality image, these defects are collectively called lens aberrations. There are two classes of aberrations: monochromatic, involving a single color and chromatic, due to the dispersion of the lens material causing diffraction of light with different wavelength [5].

So far we have dealt with thin lenses, and since this thesis is about the human eye, which is a thick lens, we shall explain a bit more about the difference between a thick and a thin lens. Although some thick lenses are made of a collection of thin lenses cemented together, for some they might consist of multiple individual thin lenses, as the case with

the human eye, for these lenses one can find the overall focal length by using the following formula [5]:

$$\frac{1}{f} = \frac{1}{f_1} + \frac{1}{f_2} \quad (9)$$

Where  $f_1$  and  $f_2$  are focal lengths of the first and second lens respectively and  $f$  is the overall focal length. This formula came to be by using the Gaussian formula to find the focal length of the two lenses separately and through algebraic substitution one can find the following formula.

## 5. Anatomy of Human Eye

### 5.1. Introduction

After going through geometrical optics, it is time to review the anatomy of the human eye and its components. Human eyes are found on either side of the face in their orbits, the orbits contain and protect the eyeballs and their accessory visual structures. The latter include: eyelids, extraocular muscles, nerves and vessels, orbital fascia and a mucous membrane called conjunctiva. Orbital fat is found filling the spaces between the eyeball and these structures and acts as cushion for protection. The eyeball contains the optical components of the visual system and is found in the anterior part of the orbit. The eyeball itself and all the anatomical structures within it have a spherical characteristic [6].

The eyeball is made of three layers, from the outer layer to the inner layer they are:

- 1) Fibrous layer, also called sclera, is a tough opaque layer which is usually seen as the white of the eye, it covers the posterior five sixths of the eyeball and is continued in the anterior one sixth as the cornea.
- 2) Vascular layer, most of this layer is the choroid plexus which provides vasculature for the eye while the anterior part of it consists of the iris and ciliary muscle.

- 3) Inner layer, this layer is also called the retina, it contains the photoreceptors and the location at which the image is formed. On the retina we can find two spots that are important, the blind spot, this is the spot at which the optic nerve leaves the eyeball and due to that it has no photoreceptors hence the name blind spot, and the other spot is the fovea, on this spot we have many special photoreceptors that are needed for acuity of vision, it is approximately 1.5mm in diameter and could be viewed as ones center of focus.

Imagining we are a ray of light, a mere photon entering the eye, the first thing we would encounter would be the cornea then the following structure in their respective order: Aqueous Humor, Pupil and the iris surrounding it, the lens and its divisions since it is made up of a cortex and a nucleus with different optical properties, the vitreous body and lastly we will get the image on the retina [6].

If we look at the eyeball structure and overall organization we find that we can divide it into two chambers named according to their position relative to the anatomical position, anterior and posterior, the posterior chamber is larger than the anterior chamber and if we look at the overall size, we can say that the posterior chamber makes up 2/3 of the eye, while the anterior chamber is only a 1/3 of the eye. The chambers contain the internal structures of the eyes and we will review them by going through each chamber separately [6].

## 5.2. Anterior Chamber

The anterior chamber consists of the following:

- 1) The cornea, a domed shaped extension of the sclera, 12 mm in diameter, it is transparent owing to the regular arrangement of its collagen fibers and its dehydrated state, it is also avascular and therefore it receives its nutrients from surrounding fluids found on the outside of the eye; (lacrimal fluid) which supplies the anterior part of the cornea, and on the inside;(aqueous humor) which supplies the posterior part of the cornea.

- 2) The aqueous humor, is a fluid found in the anterior chamber of the eye, although it is actually produced in the posterior chamber (cells found on the junction between iris and ciliary muscle) and enters the anterior chamber through the pupil, it is then drained through ducts located on the corners of the eye.
- 3) The pupil and iris, the pupil of the eye is not an existing structure rather an opening accepting light rays coming towards the eyes, it can dilate or shrink depending on the environment a person is found in, accommodating for the lack of light or excess of light. This accommodation is brought about by the contraction and relaxation of the Iris, a muscle surrounding the pupil and is pigmented differently depending on a person's genetics and origins.

### 5.3. Posterior Chamber

After passing through the pupil we have officially entered the posterior chamber with its components. The anterior chamber held the cornea, aqueous humor and ended with the pupil, while the posterior chamber contains the lens and the vitreous humor ending with the retina to which images are formed upon [6].

The posterior chamber consists of:

- 1) The lens and ciliary muscle, the lens is a transparent, biconvex structure enclosed in a capsule, it is made from a crystalline array of 25% protein and 10% lipid, attached to this highly elastic capsule we have zonular fibers, which are suspensory ligaments anchoring the lens to the ciliary muscle. The ciliary muscle that surrounds the lens is shaped like a sphincter and when it is relaxed (the diameter of the sphincter increases) the zonular fibers are stretched and force the lens to take on a more flat appearance, while when the ciliary muscle is constricted (the diameter of the sphincter decreases), the zonular fibers are relaxed and the lens due to its elasticity gains back its more spherical like appearance. The lens is one of the few parts of our bodies that are preserved without turnover of their cells and with age or disease it loses its crystalline shape and becomes

defected. Looking at a cross section we can see that the lens has two differentiable structures a cortex surrounding a denser core called the nucleus.

- 2) The vitreous humor, is a fluid enclosed in the meshes of the vitreous body, a transparent jelly-like substance found in the posterior four fifth of the eyeball, in the posterior chamber, this fluid and jelly like substance hold the retina in place and support the lens [6].

## 6. Refractive media of eyeball

Now that we have seen the anatomy of the eye we will focus more on two main structures in the eyeball, the cornea and the lens since these two structures are the major contributors to the overall refractive power of the eye.

*Table 1.*

<b>Structure</b>	<b>Index of refraction “n”</b>
Cornea	1.376
Aqueous humor	1.377
Vitreous humor	1.377
Lens	1.386

The cornea, as mentioned earlier, is an anterior continuation of the sclera, having a diameter of 12mm that is found covering the iris and the pupil, enclosing the anterior chamber anteriorly. It is transparent and domed shaped (slightly flattened to minimize spherical aberrations) as it serves as the first and strongest convex element of the eye’s optical system [2]. The interface between the air and cornea has the largest index transition, from  $n=1$  for air, to  $n=1.376$  for the cornea [5].

The lens, as mentioned earlier, is a biconvex transparent structure that serves as the second contributor to the overall refractive power of the eye, although refraction occurring at the lens is a lot less significant in its dimensions, it is still important since it allows us to focus on a near object 20cm away and then immediately focus on an “infinitely” far object, this occurs by a process called accommodation and is brought about by contraction and relaxation of the ciliary muscle surrounding the lens causing it to change its shape [5]. The structure of the lens resembles that of an onion, formed from about 22,000 very fine layers of arranged fibers, it has a size of 9mm in diameter and 4mm thick, the human lens has some remarkable characteristics differentiating it from a man-made lens, among those is its pliable and elastic characteristic that allows it to change its shape, another characteristic that is special is the fact that it has a range of index of refraction, from roughly 1.406 at the nucleus, to 1.386 at the less dense cortex

and lastly the lens's most impressive characteristic is that it has a variable focal length [2].

For near distance objects, the light rays coming into the eye are diverging at a big angle necessitating a more powerful refraction to get a good image on the retina, therefore the ciliary muscle will contract, decreasing its diameter and relaxing the zonular fibers attached to the lens by its capsule, this allows the lens to go back to its natural spherical shape to compensate for the need to increase the refractive power of the eye. The case is different when viewing a far distance object, the light rays traveling towards the eye are less divergent and adhere more to the principal axis, and therefore they require less refraction than with near distance object, thus the ciliary muscle relaxes (increasing its diameter) causing the zonular fibers to stretch and pull on the lens making it take on a more flat appearance which will decrease its refractive power.

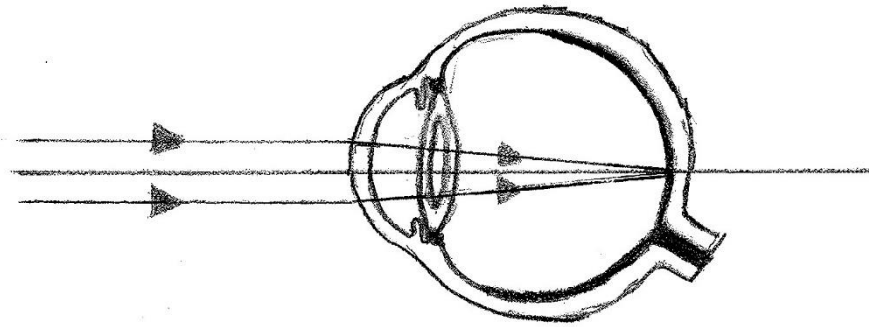

*Figure 10. Viewing a far distance.*

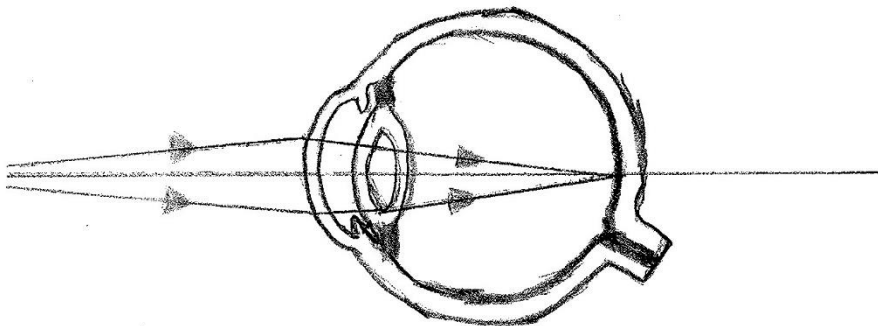

*Figure 11. Viewing near distance.*

The aqueous humor and vitreous humor also have an index of refraction, and since they are almost similar in composition, their indices of refraction have the same value of about 1.337, this might not seem important but it is, since it provides a medium between the cornea, lens and retina, that has an index of refraction closer to that of the lens and cornea, therefore, allowing the light that is refracted by them to not lose its trajectory [2].

After having mentioned the optical properties of all of the refractive structures used in the eye's optical system we shall now view it as a whole. In this part of the thesis, we will use what we call an optical model, these models are used in ophthalmology to show refractive errors and to represent the optical system of the eye. Many mathematical models of the eye's optical system are based on rough anatomical measurements and approximations, the model developed by Gullstrand, a Swedish professor of ophthalmology, so closely resembled the human eye that he won a Nobel prize in 1911, although it is useful it is also too detailed and can be simplified further for certain clinical calculations [1].

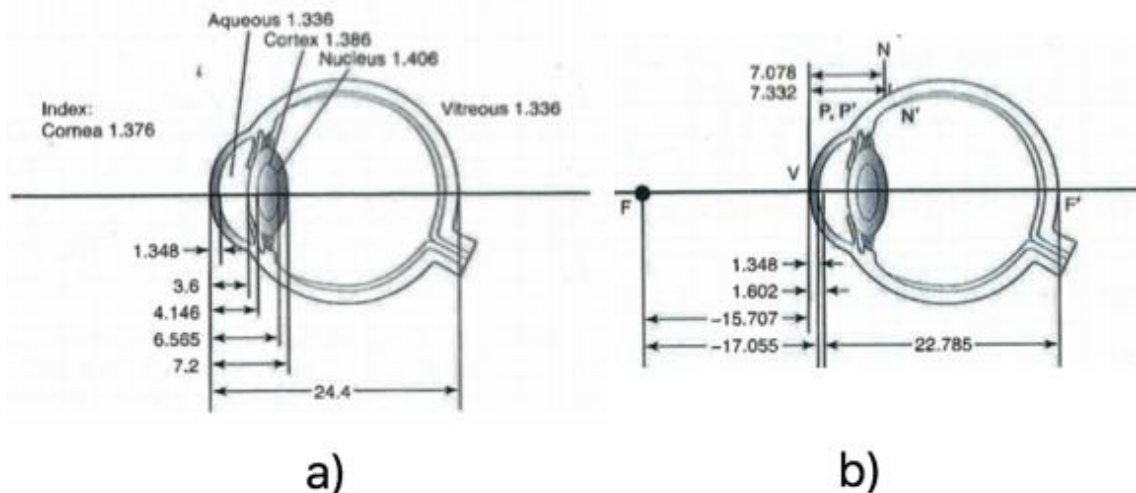

Figure 12. shows the optical constants of Gullstrand's schematic eye, this was taken from the book clinical optics, section 3 page 74. 7a shows the refractive indices of the different mediums and their positions, while 7b focuses on the positions of the cardinal points used for optical calculations. All values are in millimeters [1].



Since the principal points of the cornea and the lens are relatively close to each other, we can substitute them with a single intermediate point, similarly, the nodal points of the cornea and lens can be combined into a single nodal point located 17mm in front of the retina touching the posterior capsule of the lens. Due to this, we can view the eye as a single refracting tool, an ideal sphere shaped surface separating 2 media, air with an index of refraction of 1.000, and the eye's collective index of refraction of about 1.333, this concept is known as the reduced schematic eye [1].

Using the reduced schematic of the eye we can find the size of the image on the retina, this calculation uses the simplified nodal point, which we take as a point in which light rays entering or leaving the eye pass without deviating [1].

One can use the geometric principle of similar triangles for calculating the size of the retinal image if one knows the actual height of the object, distance from the eye to said object and distance from the nodal point to the retina. The formula is as follows [1]:

$$\frac{\textit{Retina image height}}{\textit{Object height}} = \frac{\textit{Nodal point to retina distance}}{\textit{Object to eye distance}}$$

Although the distance from the object to the nodal point should be measured, we often use a distance of the object to cornea since it is easier to measure, the distance between the cornea and the nodal point is about 5.6mm, which is usually insignificant [1]

Throughout history we can see that models have been in constant use and of course better and more accurate models have been made, although looking back at one of the first models, made by Christoph Scheiner in 1619, it is quite interesting to see that it is not that different from models coming today, even thou they were made based on animals, not humans these models where good in representing different aberrations occurring in eyes [7].

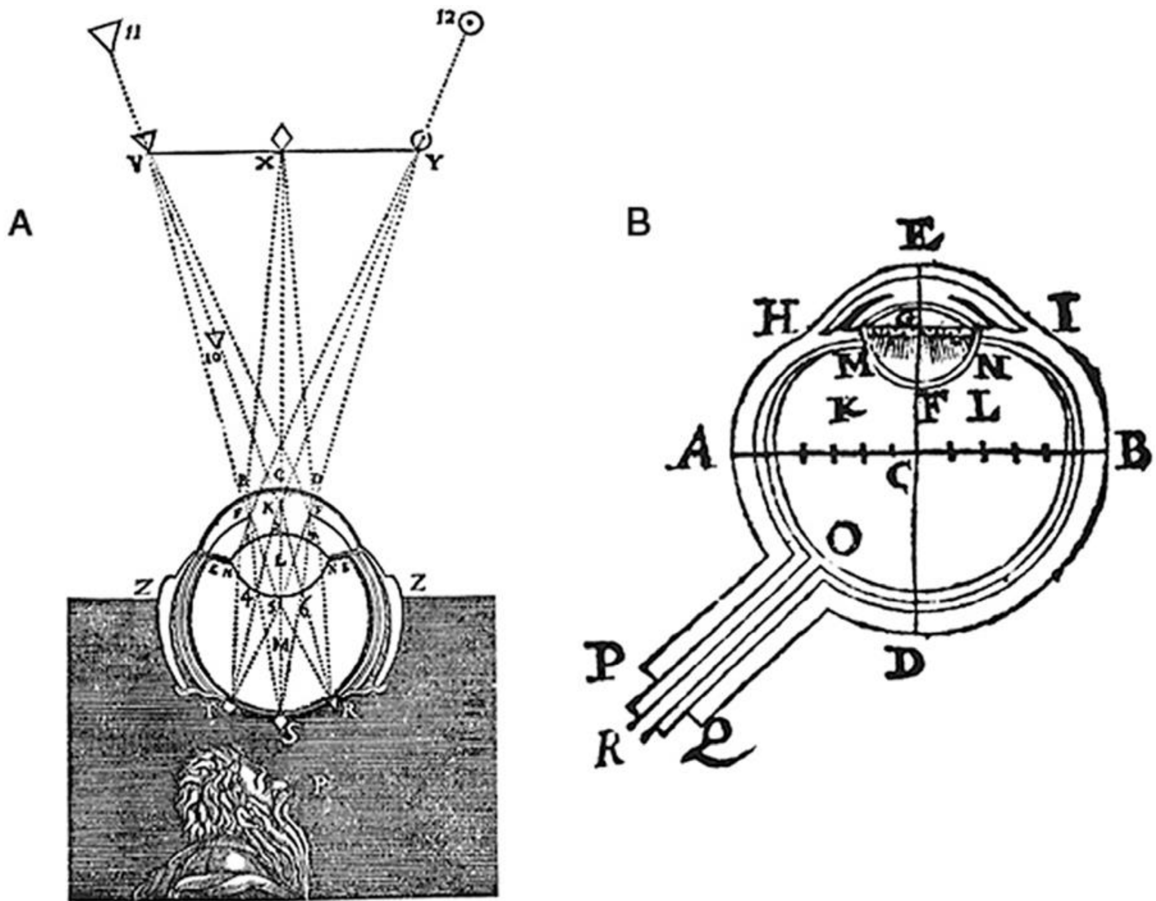

Figure 13. Model for viewing retinal image formation by Scheiner 1619 [8].

## 7. References

1. Clinical optics. In: section 3. American Academy of Ophthalmology;
2. Hecht.E, Zajac A. Optics. In: Guardino K, editor. Third Edition. 3, illustr ed. Addison-Wesley; 1998. p. 694 pages.
3. Newman J. Geometrical Optics. In: Physics of the Life Sciences [Internet]. New York, NY: Springer New York; 2008. p. 1–20. Available from: [http://link.springer.com/10.1007/978-0-387-77259-2\\_20](http://link.springer.com/10.1007/978-0-387-77259-2_20)
4. J. CD, K. JW. Physics. 5th ed. 2001.
5. Newman J. Optical Lenses and Devices. In: Physics of the Life Sciences [Internet]. New York, NY: Springer New York; 2008. p. 1–19. Available from: [http://link.springer.com/10.1007/978-0-387-77259-2\\_21](http://link.springer.com/10.1007/978-0-387-77259-2_21)
6. Moore KL, Dalley AF. Clinically Oriented Anatomy. In: 5th editio. Lipincot Wiliams & Wilkins; p. 24.
7. Clinical and Experimental Optometry. Australian Optometrists Association;
8. N. WJ. A natural History of Vision. MIT Press; 2000. 466 p.
9. University physics 13<sup>th</sup> edition, Hugh D. Young, Roger A. Freeman, Pearson.

## 8. Acknowledgment

Firstly, I would like to thank my mentor, Professor Sanja Dolanski Babic and assistant Nikola Segedin, for supporting me from the very beginning and providing me with all the tools I needed to make this thesis. Also I would like to thank my parents for their support mentally and economically, for without them I would not have been given this opportunity.

Lastly I would like to thank my friends and colleagues for their support and criticism which allowed me to improve my skills.

## 9. Bibliography

Zaki Hinnawi, born on the 22/03/1995, currently living in Zagreb, Croatia, born in Israel, graduated from a private Scottish school called Tabeetha in 2012, started attending the University of Zagreb, School of Medicine, in 2012 and graduated the year of 2018.